



DECKING INSTALLATION INSTRUCTIONS



MOST IMPORTANT FACTORS FOR A SUCCESSFUL GEODECK INSTALLATION

- **Do not butt boards end-to-end on the main area of your deck.**
 - When installing a deck that requires lengths greater than a single board (i.e., over 20'), **use our feature strip as a divider rather than butting boards end-to-end.**

- **The amount of open air space under the deck will determine which boards need to be used.** Open air space is defined as: The distance from the grade to the TOP of the joists.
 - **24" or more of open air space:** Either Tongue & Groove or Traditional boards can be used.
 - **Less than 24" of open air space:** Only Traditional boards can be used with a 1/8" space between boards. **DO NOT** use Tongue & Groove boards.

- **When using the Tongue & Groove boards, leave at least two sides of the under-deck space open for cross ventilation.** Two sides of the deck must be open or lattice only.
 - Solid cladding or skirting can be used with decks built with Traditional boards that have a 1/8" space between them.

- **All face fasteners must be located a minimum of 3/4" from the end of the boards.**

Failure to follow these instructions risks voiding the GeoDeck warranty.

Deck Components and Specifications



TRADITIONAL S4S
 Description: 5/4" x 6" S4S
 Height: 1 1/4"
 Width: 5 1/2"
 Lengths: 12', 16', 20'
 Weight: 1.9 lbs./ft.

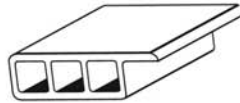

PERIMETER STRIP
 Description: 6/4" x 6"
 Height: 1 1/2"
 Width: 5 1/2"
 Length: 12'
 Weight: 1.6 lbs./ft.

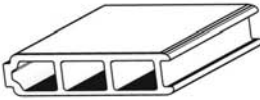

TONGUE & GROOVE
 Description: 5/4" x 6"
 Height: 1 1/4"
 Width: 5 3/4"
 Lengths: 12', 16', 20'
 Weight: 1.85 lbs./ft.

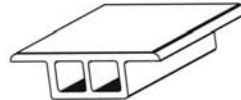

FEATURE STRIP
 Description: 6/4" x 6"
 Height: 1 1/2"
 Width: 5 1/2"
 Length: 12'
 Weight: 1.4 lbs./ft.



2" X 8" COMMERCIAL
 Description: 6/4" x 8"
 Height: 1 1/2"
 Width: 8"
 Lengths: 16', 20'
 Weight: 2.8 lbs./f

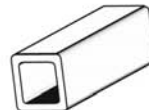

BALUSTERS
 Description: 2" x 2"
 Height: 1 3/4"
 Width: 1 3/4"
 Lengths: 32", 38"
 Weights: 32" 2.3 lbs., 38" 2.6 lb

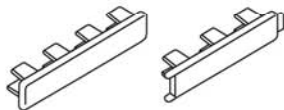

*End Caps available for all profiles

END CAP*
 Height: 1 1/4"
 Width: 5 1/2"
 Length: 1"
 Weight: .2

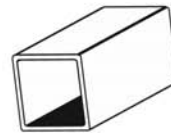

4" X 4" POST SLEEVE
 Height: 4.315"
 Width: 4.315"
 Length: 8'
 Weight: 17.6 lbs.

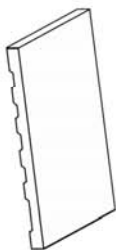

FASCIA BOARD
 Height: 7/16"
 Width: 12"
 Length: 12'
 Weight: 2.5 lbs

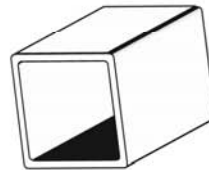

6" X 6" POST SLEEVE
 Height: 6.410"
 Width: 6.410"
 Length: 12'
 Weight: 39.5 lbs.



POST CAP
 Height: 4"
 Width: 4"
 Weight: .22 lbs.
 Notes: Standard Post Cap
 also available in 6" x 6"



POST BASE TRIM
 Height: 4"
 Width: 4"
 Weight: .20 lbs.
 Notes: Standard Post Base Trim
 also available in 6" x 6"

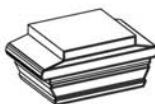

DECORATIVE POST CAP
 Height: 4"
 Width: 4"
 Weight: .22 lbs.

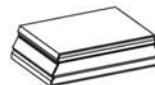

DECORATIVE POST BASE TRIM
 Height: 4"
 Width: 4"
 Weight: .20 lbs.

TABLE OF CONTENTS

General Introduction	4
Local Building Codes	4
Tools Needed	4
Scheduling Your Project	4
Unloading, Storage, and Handling	4
Cautions	4
Expansion and Contraction	5
Sub-Structure Framing	5
Installing Feature & Perimeter Strips ..	5
Blocking	6
Joist Spacing	6
Open Air Space Below Deck	6
Cross Ventilation	6
Deck Drainage	4
Water Drainage Systems	4
General Guidelines	7
Board Layout	7
Board Spacing	7
Board Gapping	7
Fasteners	8
Installation	10
Parallel or Perpendicular Decking ...	10
Diagonal Decking	11
Feature and Perimeter Strips	12
Fascia Boards	12
Warranty	13

CLEANING YOUR GEODECK

Through regular use and atmospheric conditions, GeoDeck™ may become dirty and require light cleaning to keep it looking fresh as well as to allow Tongue & Groove boards to drain properly. Periodic cleaning will help keep GeoDeck looking its best.

A pressure washer may be used with a fan-tip, and the spray should be consistent with the grain of the product. Be careful not to damage the boards and follow proper safety precautions. Most stains can be removed with a general-purpose household cleaner, concentrated dish soap or laundry detergent and/or degreaser according to manufacturer's instructions. Remember that fresh stains are usually easier to remove than ones that are allowed to set.

Scratches

Simply use a stainless steel wire brush to remove scratches. A few strokes along the grain will most likely refresh the GeoDeck board.

Removing Oily Stains

For oily stains such as gasoline, butter, mayonnaise, etc., use concentrated dish soap, laundry detergent, or composite deck cleaners along with a plastic bristled scrub brush.

Removing Microbial Stains

Microbial stains, such as algae and black mold, do not damage GeoDeck boards. For the most part, algae and black mold sit on the surface and consume pollen without degrading the board. These types of stains can be removed by the use of a pressure washer, plastic bristled scrub brush, and cleaners designed to remove mold and mildew.

For specific product recommendations to clean your deck with as well as other tips, please go to www.GeoDeck.com.

GENERAL INTRODUCTION

GeoDeck decking boards come in three profiles:

- **Two 5/4" profiles:** Traditional (S4S) and Tongue & Groove
 - Available in 12', 16' and 20' lengths
- **One 6/4" profile:** 2x8 Commercial
 - Available in 16' and 20' lengths

GeoDeck trim boards come in two profiles:

- **Feature and Perimeters Strips**
 - Available in 12' lengths

GeoDeck comes in a variety of colors. See www.GeoDeck.com for more details.

The complete GeoDeck system includes boards, post sleeves, railings, balusters, end caps, post caps, post base trim, and handrail collars — everything needed to create a great-looking deck.

All GeoDeck boards manufactured by Green Bay Decking have laser identification on the edge of each board, every 4 feet. This identification includes the manufacturer's name, the date the product was manufactured, and the ICC report number - ESR 1369.

Since GeoDeck is made from a combination of reclaimed paper by-product, rice hulls (a rapidly renewable resource), and other high-quality materials, its properties differ from those of wood products. Therefore, GeoDeck has different handling and installation requirements, which need to be taken into consideration during the planning of your deck installation.

The following illustrated instructions have been provided to help you understand and take advantage of these differences with appropriate installation techniques. Following these instructions along with good building practices will deliver the highest quality installation. Failure to follow these instructions and the instructions outlined in ICC-ES ESR-1369 also risks voiding the GeoDeck warranty.

Local Building Codes

Installation shall follow all local codes and good construction practices when designing and installing the deck sub-structure. Most municipal building codes have specific deck construction requirements. Failure to follow local building codes, including filing plans and scheduling inspections with the municipal building inspector, may result in costly post-construction modifications. There are many excellent deck construction books on the market, many of which are available at your local lumberyard. In addition to local codes, be sure to follow the instructions in this manual that specifically pertain to the GeoDeck products. Failure to do so will void your GeoDeck warranty.

Tools Needed

Typical woodworking tools are required. No pre-drill or special drill bits required. Can be installed either using composite decking screws, or color-matched nails in a pneumatic nailer.

SCHEDULING YOUR PROJECT

Unloading, Storage, and Handling of GeoDeck

GeoDeck boards shall be stored on a dry, flat surface with support every 48 inches. Do not stack GeoDeck more than four skids high. Cutting and drilling of GeoDeck does not produce respirable dust. However, it is good practice to always wear protective equipment such as safety glasses and hearing protection when operating power equipment.

Cautions



Store Flat



No Dumping



Do Not Burn



Protective Gear

Expansion and Contraction

Every material expands and contracts with temperature changes, and composite decking is no exception. Avoid potential problems by budgeting time for proper acclimation of GeoDeck to local temperatures. Expansion and contraction is not a product defect and not covered under the GeoDeck warranty.

It is best to mark, cut, and install boards when they are all at roughly the same temperature.

It is recommended that all boards be kept as cool as possible by keeping them out of direct sunlight. **Boards that have spent several hours in the sun will have expanded more than those kept in the shade, and consequently will contract more when they cool down.**

If possible, install GeoDeck during the coolest part of the day. Although the ideal temperature for installation is 60 degrees Fahrenheit, this is not always going to be possible. However, there are steps that can be taken to help reduce the effects of expansion and contraction such as storing boards in the shade and making final cuts after boards have cooled.

SUB-STRUCTURE FRAMING

Installing Feature & Perimeter Strips

Layout your deck using current framing techniques outlined in the International Residential Code (IRC), as well as local code requirements.

In addition to standard framing practices, additional blocking is required as outlined in this section. The cutaway detail graphic shows the joist, 2x4 spacer, and blocking border. This framing allows the GeoDeck™ boards, Perimeter Strips and Feature Strips a solid foundation to rest on.

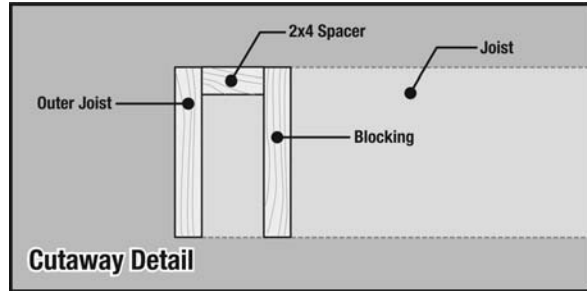

The following two illustrations show how to complete a corner with and without a post using the same framing techniques.

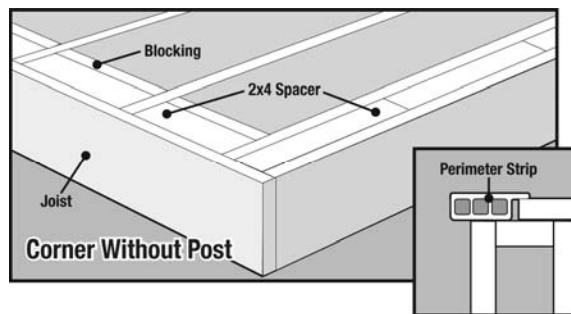
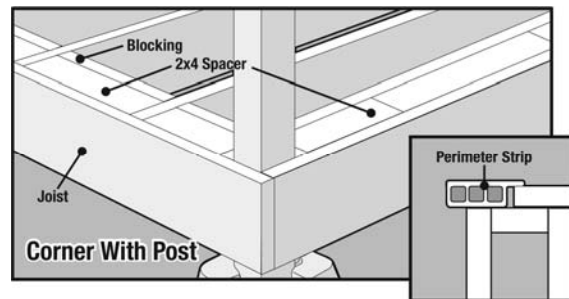

The intermediate joist is the framing necessary for Feature Strips.

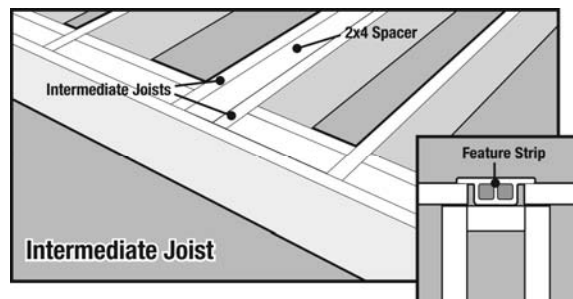

Blocking

Center blocking ties the joist together to complete the framing. It will keep joists from twisting and bowing and keep the deck square. Blocking should be installed every 6 ft. along joist, or if less than 12', mid-span.

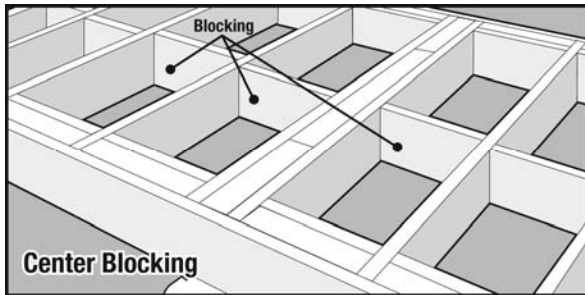

Joist Spacing

Joists should be spaced no more than 24" on-center for conventional joist dimensions, or 22.5" edge to edge for nontraditional sub-framing materials. If applying deck boards diagonally across joists, the joist spacing should be reduced by 4". Be certain that the joist system is properly squared and secured with center blocking.

Open Air Space Below Deck

The amount of open air space under the deck will determine which boards need to be used.

Open air space is defined as: The distance from the grade to the BOTTOM of the joists.

- **24" or more of open air space:** Either Tongue & Groove or Traditional boards may be used.
- **Less than 24" of open air space:** Only Traditional boards shall be used with a 1/8" space between boards. **DO NOT** use Tongue & Groove boards.

Cross Ventilation

When using the Tongue & Groove boards, a minimum of two sides of the under-deck space must be open for cross ventilation. In addition, the underside of the deck shall not be enclosed with solid cladding or skirting. Lattice is recommended.

Solid cladding or skirting may be used with decks built with Traditional boards that have a 1/8" space between them.

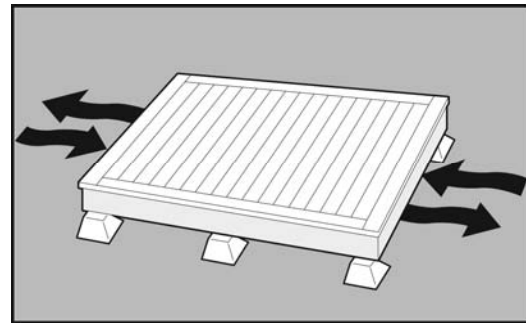

Deck Drainage

Slope the deck slightly (1/16" per foot) away from the house for water run-off, particularly for Tongue & Groove boards. Proper flashing of the ledger board is essential. Be certain that water drains from the deck and does not leave standing pools.

Water Drainage Systems

Water drainage systems such as an EPDM type membrane or an under deck drainage system, may be used with the Traditional board. **Do not use Tongue & Groove boards with any water drainage system.**

The Traditional Board shall be installed with a minimum 1/8" space between board edges. This will ensure adequate water drainage and proper ventilation.

GENERAL GUIDELINES

Board Layout

Do not butt boards end-to-end on the main area of your deck:

On the main area of your deck, butting GeoDeck boards end to end is not permitted. When installing a deck that requires lengths greater than a single board (i.e., over 20'), use our feature strip as a divider rather than butting boards end-to-end.

Do Not

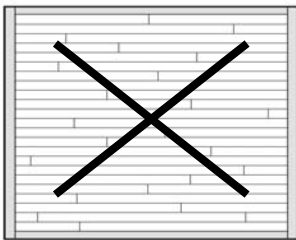

Butting Perimeter or Feature Strips:

Perimeter Strips will most likely need to be butted to picture frame the outer edges of the deck. If the deck has a rail system, we recommend you butt the Perimeter Strips at the post.

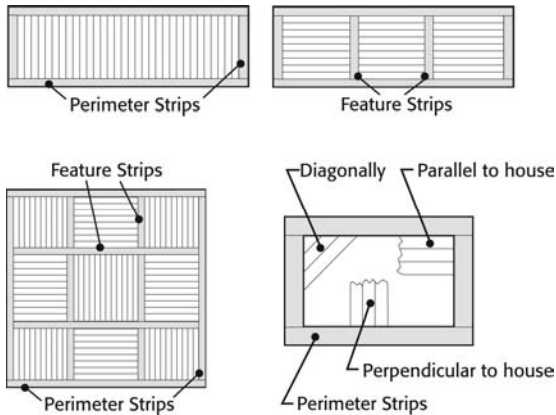

Board Spacing

Whenever a deck board meets the wall of a dwelling, leave a **1/8" space** for air circulation and to prevent water accumulation. Siding or moulding can later conceal this gap.

Allow a **3/16" spacing gap** between the deck board and the wood newel post. The GeoDeck post sleeve and post base trim when placed over the wood newel post, will cover the gap.

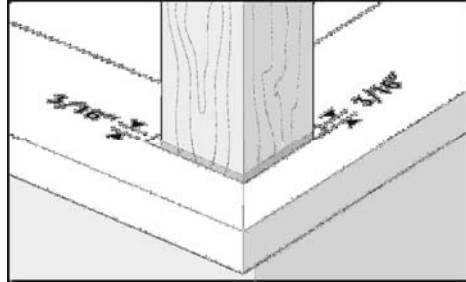

Board Gapping

Keep the deck boards square as you proceed. Check for square every few boards and adjust the board-to-board gap as necessary to compensate. Maintain a minimum board-to-board gap to assure proper drainage of rain and snow melt.

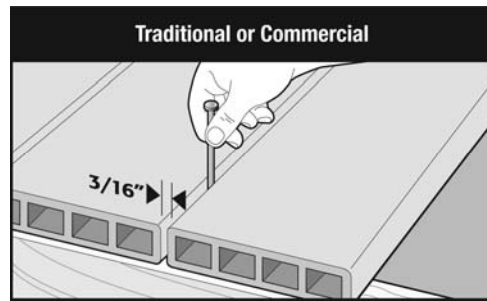

When installing Tongue & Groove boards, always use a spacing guide to ensure a minimum of **~1/32"** of space between boards. **An installation that is too tight will restrict water run-off and may cause buckling, damaging the board and voiding the warranty.**

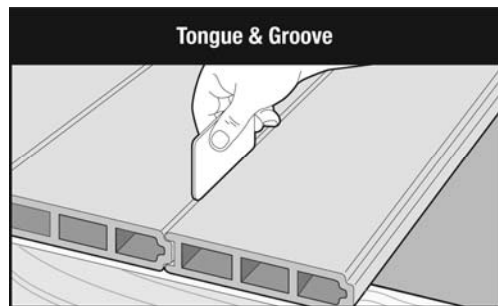

Fasteners

Avoid fastening within 3/4" from the ends of the boards to prevent cracking.

See www.GeoDeck.com for brand-specific fastener recommendations.

Applies to all board types: If the look of visible fasteners is not wanted, consider using either a hidden fastener system, GeoDeck Tongue & Groove boards, or splitless ring shank siding nails that match GeoDeck colors.

A pneumatic nail gun *with an adjustable tip*, such as a siding/fencing nailer, greatly speeds installation. Adjust the air pressure (between 90 and 110 psi) to ensure consistent pressure for proper nail penetration. Check for correct pressure by testing the nail gun with the chosen fastener on a scrap board.

Traditional:

Use #8 or #9 stainless or coated "trim head" screws 2-1/2" (or longer), or 8d 2-1/2" (or longer) stainless or coated ring shank "siding" nails.

Apply a minimum of two fasteners on every joist, and three at the ends of each board.

If hand nailing, a 2-1/2" 8d small head stainless steel ring shank nail provides superior holding with minimal fastener exposure.

If using a Feature Strip, allow the ends that will butt the Feature Strip to run long and overlap the opening where the Feature Strip will be installed. These ends will be trimmed to length later. (See Feature & Perimeter Strip Installation on page 12.)

2 x 8 Commercial:

Use #10 stainless or coated "trim head" screws at least 3" long, or 10d 3" (or longer) stainless or coated ring shank "siding" nails.

Apply a minimum of three fasteners on every joist.

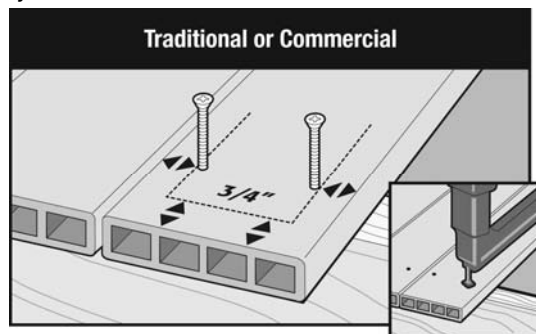

Tongue & Groove:

Use #8 or #9 stainless or coated "trim head" screws 2-1/2" (or longer), or 8d 2-1/2" (or longer) stainless or coated ring shank "siding" nails.

Apply one fastener on every joist. It is also recommended to apply two fasteners through the face at the end of each board.

Fasteners should be driven through the tongue at a 55° to 60° angle to the horizontal, through the tongue-to-shoulder junction, and into the joist below. Be careful to avoid forcing Tongue & Groove boards together, particularly when using screws.

Hand fit the boards only, using a credit card or an item of similar thickness (~1/32") as a spacing guide. An installation that is too tight will restrict water run-off and may cause buckling.

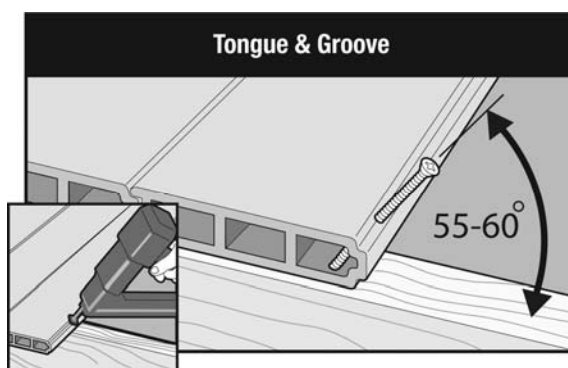

Perimeter Strips and Feature Strips:

Use #8 or #9 3" (or longer) stainless or coated "trim head" screws, or 8d 3" (or longer) stainless or coated ring shank "siding" nails.

Apply the fasteners through the 5/4 hollow portion of the board. **Do not fasten through the flat edge that overlaps the deck boards.**

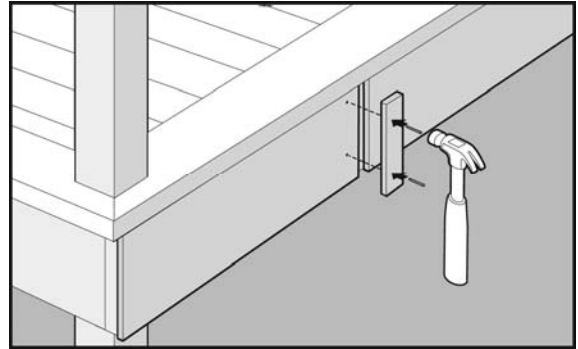

Apply 2 fasteners every 16 to 24 inches. Avoid fastening within 3/4" from the ends of the boards. Trim head screws can be driven just below the surface of the board and hidden by using a hammer to tap the decking material over the screw head.

Fascia:

Use a minimum of three fasteners every 12". If the fascia has been ripped down to 6" wide or less, then use a minimum of 2 fasteners every 12".

The same fasteners used on the deck may be used on the fascia.

Use corner moulding when two fascia boards meet at an angle. Corner moulding can be fashioned from other GeoDeck stock board pieces.

To join two or more pieces of the fascia board, butt the boards with a 1/8" to 3/16" gap and cover the gap with a 1" to 2" piece of trim nailed vertically. This allows the board to slide behind and conceal any contraction and expansion.

PARALLEL OR PERPENDICULAR DECKING INSTALLATION

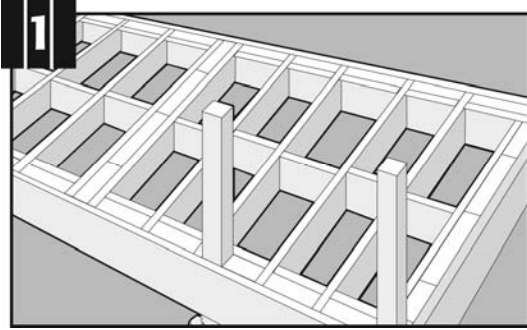

Start decking. Leave 1/8" between house; cover later with siding or moulding

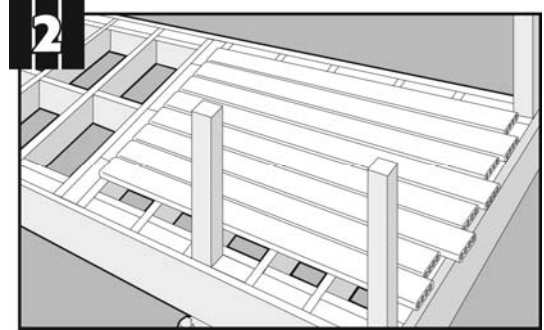

Install boards with extra to be trimmed later.

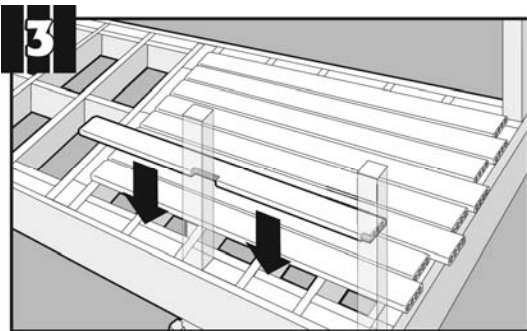

Mark and cut boards next to posts or house to actual length before attaching. The skill saw will not cut up to these areas.

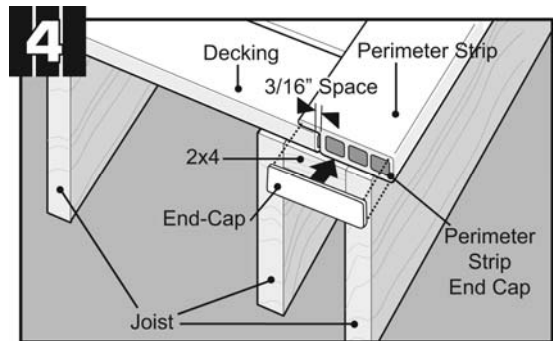

Boards should overlap joist (allowing 3/16" for expansion / contraction) where Perimeter Strips and Feature Strips will be added.

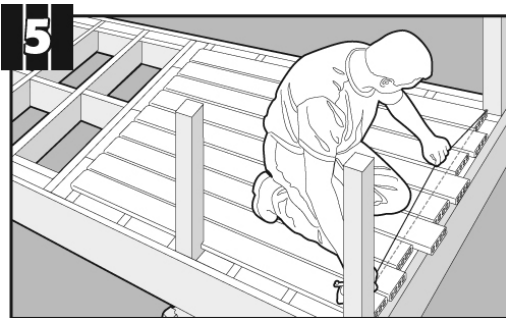

Snap a chalk line to indicate final cut length. Recommend using white or blue chalk.

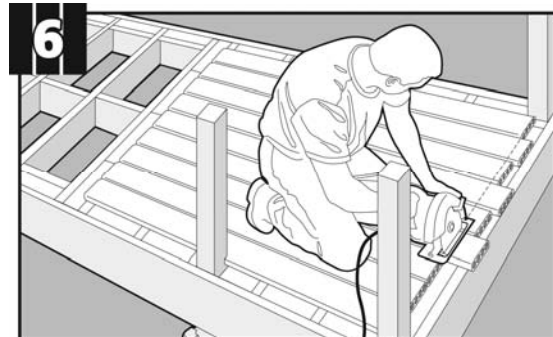

Cut off excess

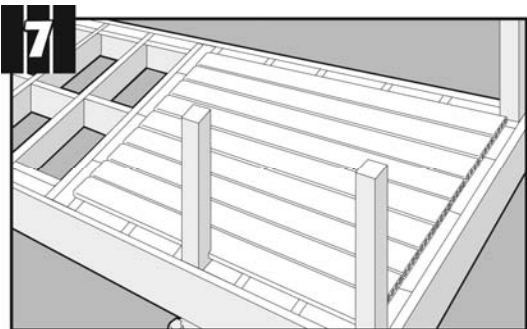

Install Feature and Perimeter Strips when all decking is complete.

DIAGONAL DECKING INSTALLATION

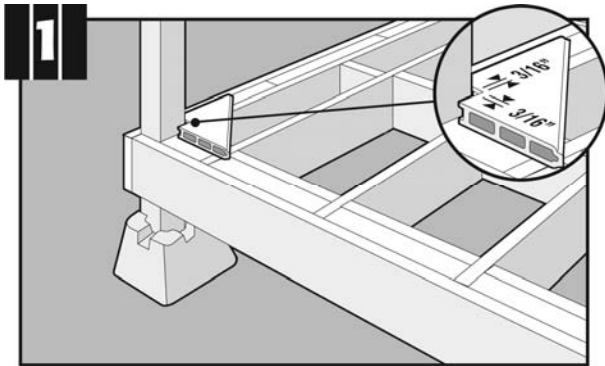

1 Cut corner piece and attach for guide. Always fasten $\frac{3}{4}$ " from edge of board.

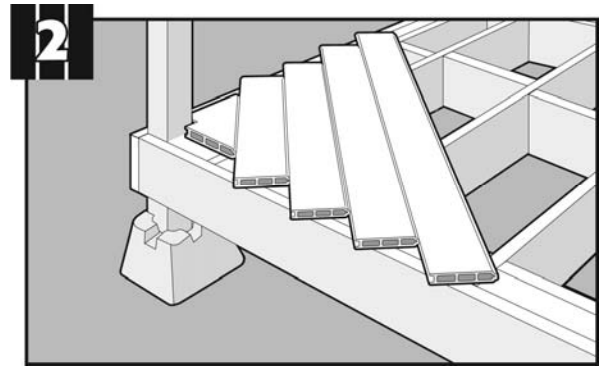

2 Cut and attach boards as you go. Trim excess *after* all boards are attached.

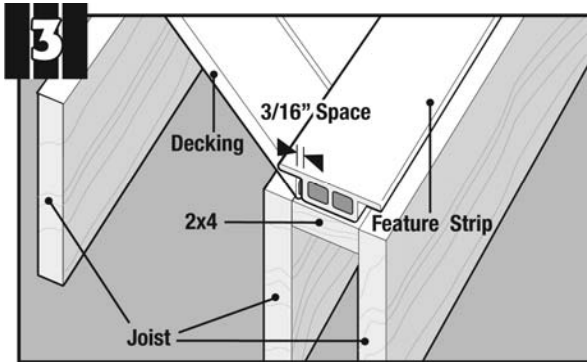

3 Boards should overlap joist (allowing $\frac{3}{16}$ " for expansion / contraction) where Perimeter Strips will be added.



4 Snap a chalk line on all edges to indicate final cut length.

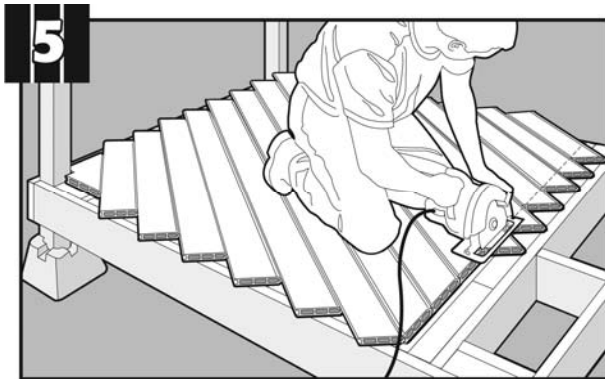

5 Cut off excess.

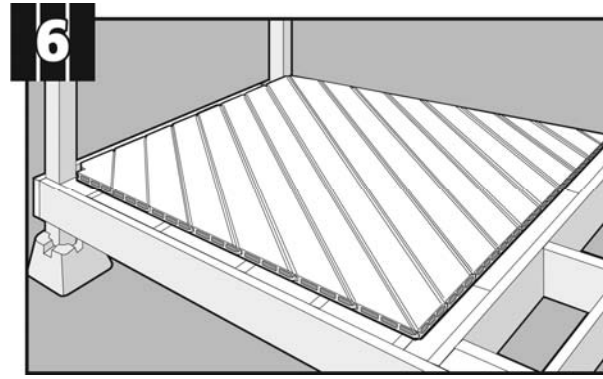

6 Install Feature and Perimeter Strips when all decking is complete.

FEATURE STRIP, PERIMETER STRIP & FASCIA BOARD INSTALLATION

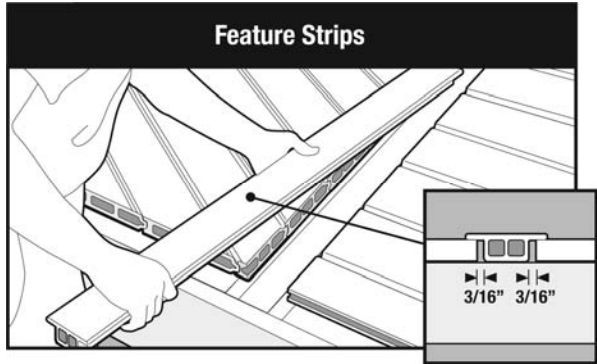

Feature Strips are placed between decking joints.

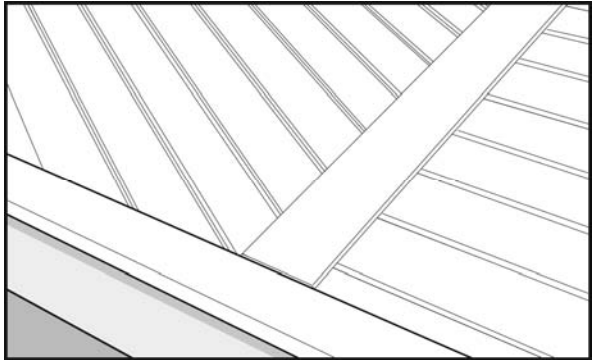

Completed deck after all Feature and Perimeter Strips have been installed.

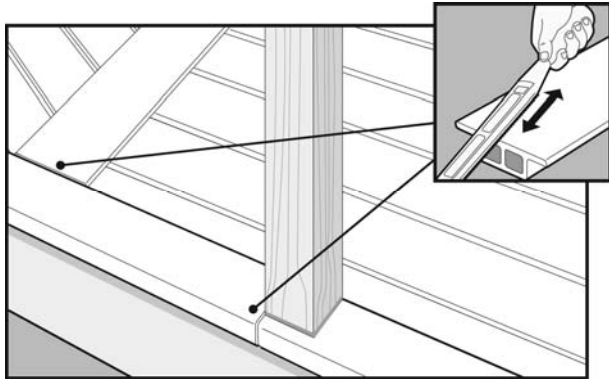

File or route edges when butt joints are unavoidable. To minimize the appearance of expansion and contraction, always butt Perimeter Strips at a post. The joint will be less visible when behind a post and covered with base trim.

Fascia Board Installation

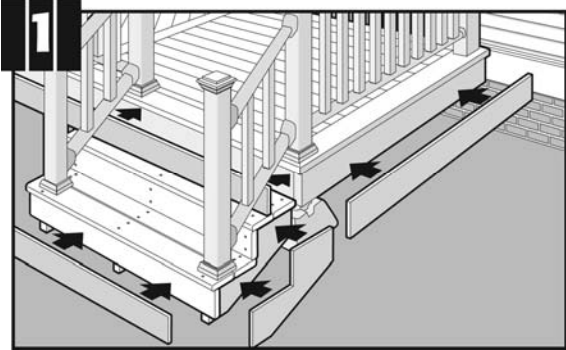

Measure areas to be covered with fascia. Cut and attach with three fasteners every 12" using same fasteners used for decking. If the fascia is 6" wide or less, two fasteners every 12" should be used.

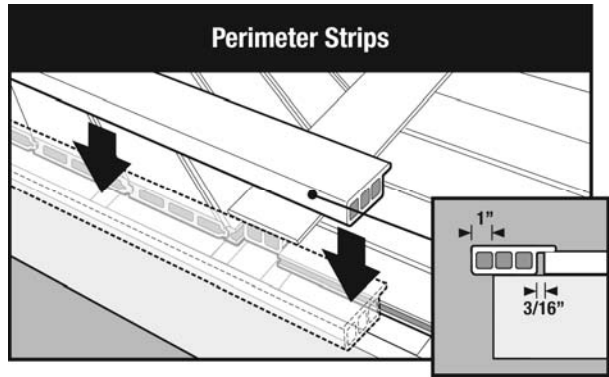

Perimeter Strips are placed around outer edge of decking. Allow for a maximum overhang of 1".

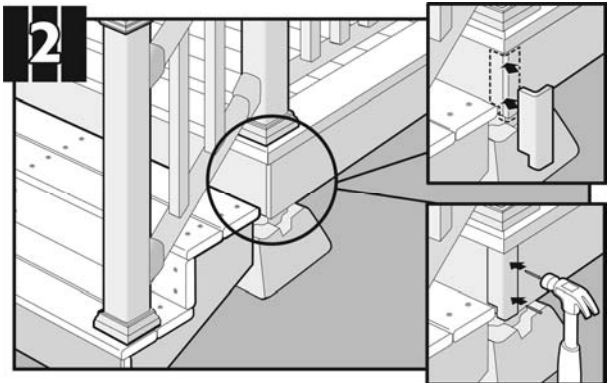

Baluster or post sleeve material can be used to cover corners. Attach with brads on one side only to allow for expansion and contraction.



GeoDeck™

Limited Warranty

Congratulations! As a GeoDeck owner, you have made a wise investment and you are protected by our twenty-year limited warranty, which provides coverage against:

- *Splintering and Splitting*
- *Rot and Decay Damage*
- *Termite Damage*

Green Bay Decking, LLC (hereinafter "Manufacturer") WARRANTS that its GeoDeck® products are manufactured from recovered cellulose and plastic, and will not rot, split or suffer structural damage from termites or fungal decay for a period of 20 years from the time of shipment to customer.

MANUFACTURER'S LIABILITY UNDER THIS WARRANTY IS LIMITED SOLELY TO REPLACEMENT OF DEFECTIVE GEODECK PRODUCTS OR REFUND, WITH THE FIRST 10 YEARS NON-PRORATED AND THE SECOND 10 YEARS ON A STRAIGHT-LINE DEPRECIATING BASIS, AT MANUFACTURER'S OPTION. Purchaser's sole and exclusive remedy for any claim whatsoever, whether in contract, warranty, tort or strict liability, arising out of the use, storage or possession of GeoDeck products, including without limitation any claim that GeoDeck products failed to perform as warranted, shall be replaced with substituted GeoDeck products or completely refunded within the first 10 years with the second 10 years based on a straight-line depreciating basis, at Manufacturer's option. To obtain replacement or refund, the original owner must submit its claim together with this warranty certificate, the original purchase invoice indicating the date of purchase, pictures of the defective GeoDeck products, and a detailed written description to GeoDeck, 1518 South Broadway, Green Bay, WI 54304.

THE WARRANTY SHALL NOT APPLY TO GEODECK PRODUCTS THAT HAVE NOT BEEN INSTALLED IN ACCORDANCE WITH MANUFACTURER'S AND ICC GUIDELINES (REPORT NO. ESR-1369, DATED AUGUST 1, 2008 AND LEGACY REPORT NO. #21-71, DATED DECEMBER 3, 2005). This warranty shall not cover defects due to (i) natural disasters, including fire, smoke, water, earthquake, lightning or static electricity; (ii) causes external to the GeoDeck product such as, but not limited to, weather; (iii) the neglect, abuse, misuse (including faulty installation, repair or maintenance by other than Manufacturer), improper storage of the GeoDeck product or other failure to comply with the instructions set forth in the documentation and/or manual accompanying the GeoDeck product; (iv) a modification of the GeoDeck product not provided by Manufacturer; (v) a malfunction of any product not provided by Manufacturer with which the GeoDeck product is used or combined; (vi) use, modification or other treatment of the GeoDeck product in a manner for which it was not designed or intended; (vii) defects in articles purchased by Manufacturer and resold by it without alteration and defects in materials purchased by Manufacturer which cannot be discovered by warranty factory inspection; (viii) placement under or subjection to abnormal use conditions; or (ix) normal wear and tear. This warranty does not cover product defects on installed decks that were apparent at or prior to installation.

MANUFACTURER'S WARRANTY SHALL APPLY ONLY TO GEODECK PRODUCTS. IN NO EVENT SHALL MANUFACTURER BE LIABLE FOR LABOR OR OTHER EXPENSES INCURRED BY THE PURCHASER, OR SPECIAL, INCIDENTAL, EXEMPLARY OR CONSEQUENTIAL DAMAGES OF ANY KIND WHATSOEVER. MANUFACTURER'S LIABILITY ARISING OUT OF THE MANUFACTURE, SALE OR SUPPLY OF THE GEODECK PRODUCTS OR THEIR USE, WHETHER BASED UPON WARRANTY, CONTRACT, TORT OR OTHERWISE, SHALL NOT EXCEED THE ACTUAL PURCHASE PRICE PAID BY THE PURCHASER FOR THE GEODECK PRODUCTS.

Purchaser acknowledges that the GeoDeck products are not structural lumber and therefore may not be used as such. PURCHASER IS SOLELY RESPONSIBLE FOR DETERMINING THE SUITABILITY FOR USE OR APPLICATION OF ANY GEODECK PRODUCT, OR WHETHER GEODECK PRODUCTS MEET REQUIREMENTS OF APPLICABLE BUILDING CODES OR SAFETY CODES FOR SPECIFIC APPLICATIONS.

No person or entity is authorized by Manufacturer to make and Manufacturer shall not be bound by any statement of representation as to the performance of GeoDeck products other than what is contained in this warranty. This warranty shall not be amended or altered except in written instrument signed by Manufacturer and Purchaser.

THE FOREGOING WARRANTY IS EXCLUSIVE AND IN LIEU OF ANY OTHER WARRANTIES WITH RESPECT TO GEODECK PRODUCTS, EXPRESSED OR IMPLIED, INCLUDING WITHOUT LIMITATION, ANY IMPLIED WARRANTY OR MERCHANTABILITY, FITNESS FOR A PARTICULAR PURCHASE OR NON-INFRINGEMENT. Laws from time to time in force in certain jurisdictions may imply warranties that cannot be excluded or can only be excluded to limited extent. This warranty shall be read and construed subject to any such statutory provisions. This warranty gives you specific legal rights. You may have other rights, which vary from state to state. To activate the warranty, please fill out and send the warranty card within 30 days of purchase.

This warranty certificate was issued on: _____.

Effective May 1, 2009



Product Features

Superior Color Retention

Strength & Durability

Low Maintenance

Eco-Friendly

Easy To Install

For The Pros

Our unique tongue & groove board requires no hidden fastener system

Our boards are double-sided and finished the same way

Our traditional S4S and T&G boards are ICC rated for 24" on center

Our 2x8 commercial board is ICC rated for 30" on center

Boards can be used for any decking styles including diagonal, octagon and herringbone patterns

For the most up-to-date installation instructions, please visit our website at
www.GeoDeck.com

Green Bay Decking, LLC

1510 South Broadway
Green Bay, WI 54304
(877) 804-0137